

Housing: die-cast aluminium with wide cooling fins.

Reflector: pressed prismatic aluminium, anodised (3µ) and polished for higher luminous efficiency.

Diffuser: 5 mm thick, thermal shock and impact resistant protective tempered glass and vandal resistant.

Standard supply: complete with IP67 airtight connector for mains connection.

On request: DIMM DALI and 1-10V versions.

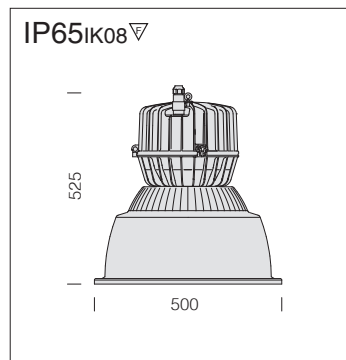

LED: Power factor $\geq 0,95$
Luminous flux maintenance 70%
>60.000h (L70B50)

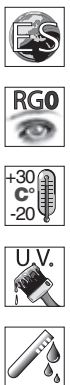
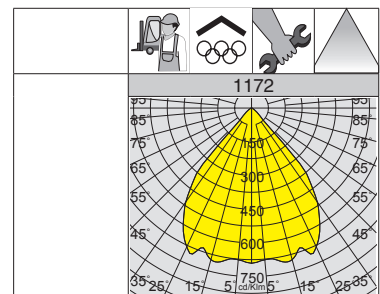

1172 Argon					
		CLD CELL		W	LED (Tp=25°C)
wattage	colour	weight	code		K - ølm - CRI
LED COB	s. silver	9.00	322652-00	115	5000K - 15900lm - CRI>70
LED COB	s. silver	9.00	322653-00	115	4000K - 14000lm - CRI>80

acc. 1122 protection guard	
0.60	321012-00
Black plastic-coated steel rod protection guard. Screw mounting.	

