

**Reflector with switching device**

On request, the series Photon can be supplied with an installed electronic switching device (CLA), which turns on the auxiliary lamp (ALO 100 E27) until the main lamp is fully operating, to prevent any interruption of the light supply in case of hot start. Supplied with E27 lampholder; lamp not included.

In this case the price of the luminaire is obtained by adding version CNRL and the CLA device, and should not be calculated per pallet.

**additional charge. \* In your order please specify specially made reflector with equipment -79).**

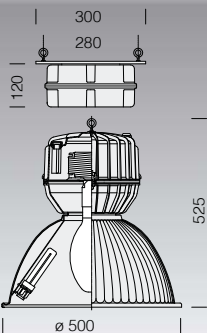
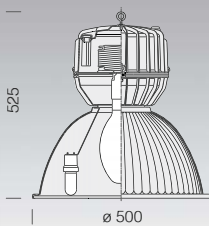

**Box acc. 1175 code 997659**

To be used when purchasing industrial floodlights in EM, sub-code -07. Reflectors with sub-code -07 come with an FLC 18D lamp, G24q2 connection for emergency switching on version. On request, FLC 26D/E lamp.

**Quick connection: using sub-code -0064 after the Disano code, customers may request reflectors equipped with quick-connection device. This device is recommended when fast installation is required. Effective in saving time and costs.**



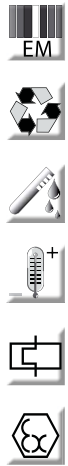
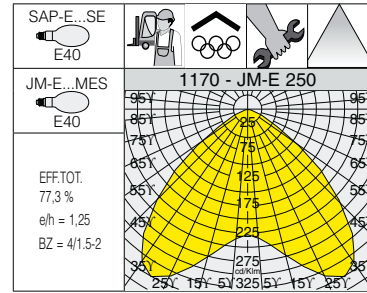
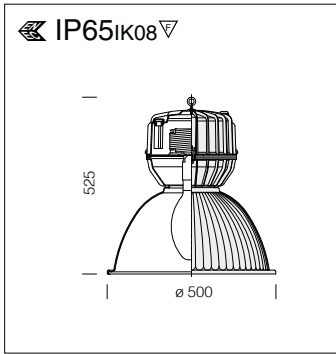

**Housing:** die-cast aluminium with wide cooling fins.

**Diffuser:** 5 mm thick, thermal shock and impact resistant protective tempered glass and vandal resistant.

**Reflector:** pressed prismatic aluminium, anodised (3µ) and polished for higher luminous efficiency.

**Coating:** graphite polyester powder coating, resistant to corrosive and saline environments.

**Standard supply:** the reflector remains hooked to the fixture by means of a suspension chain. Removable gear tray for easy maintenance.

**Equipment:** environment-friendly silicone rubber gasket.

Fibreglass nylon cable gland, Ø 1/2 gas (cable min. Ø9, max Ø12).

1170 Argon - with glass						
		CNRL		CNRL-E		Lamps (Ta=25°C)
wattage	colour	weight	code	weight	code	Kelvin - ølm - Ra
JM-E 250	graphite	8.60	322643-00	8.60	322643-07	4500K - 18000lm - Ra 2b
JM-E 400	graphite	9.60	322644-00	9.60	322644-07	4500K - 32500lm - Ra 2b
SAP-E 250	graphite	8.60	322645-00	8.60	322645-07	2000K - 31200lm - Ra 4
SAP-E 400	graphite	9.60	322646-00	9.60	322646-07	2000K - 54000lm - Ra 4

Option to attach protective guard acc 1122. Easy to mount with a single hook (eyebolt).

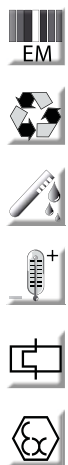
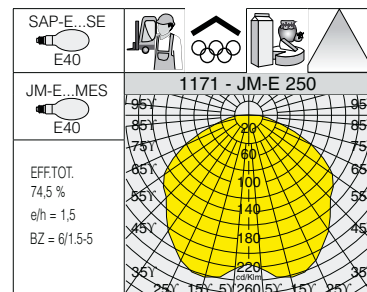

**Diffuser:** 5 mm thick, thermal shock and impact resistant protective tempered glass, and vandal resistant, V2 self-extinguishing, UV-stabilised clear polycarbonate diffuser, prismatic inside for better light control and smooth outside.

1171 Argon - with diffuser						
		CNRL		CNRL-E		Lamps (Ta=25°C)
wattage	colour	weight	code	weight	code	Kelvin - ølm - Ra
JM-E 250	graphite	8.40	322743-00	8.40	322743-07	4500K - 18000lm - Ra 2b
SAP-E 250	graphite	8.40	322745-00	8.40	322745-07	2000K - 31200lm - Ra 4

Option to attach protective guard acc 1122. Easy to mount with a single hook (eyebolt).

acc. 372 quick connec. socket	
black	998043-00
Always use with wire or tube. Cable gland with inlet cable with 16A and minimum diameter 9 and maximum dia. 12. <b>10 pcs. per pack.</b>	

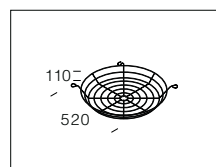
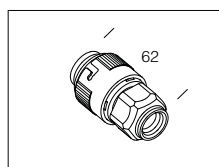

acc. 1122 protection guard	
0.60	321012-00
Black plastic-coated steel rod protection guard. Screw mounting.	